



BAYweb Integrator Owner's Manual



[S/N LABEL HERE]

BAYweb Integrator Model BW-BCU3 Owner's Manual
Copyright © 2009-2011 Bay Controls, LLC
Part Number: BW-BCU3DOC
Revision: 1.2 February 8, 2011

BAYweb is a registered trademark of Bay Controls, LLC.
Patent pending technologies are used in the BAYweb Integrator.

Table of Contents

Introduction.....	1
About This Manual.....	1
Limited Warranty.....	2
Limitation on Liability.....	2
Unauthorized Repair.....	2
BAYweb Integrator.....	3
Monitoring Points.....	3
Alert Handling.....	3
Control Points.....	4
Installation.....	5
Overview.....	5
Install BAYweb Integrator.....	6
Connect to the Internet.....	7
Connecting Modbus.....	9
Modbus.....	9
Serial Modbus.....	9
Modbus TCP (Ethernet).....	9
Configuration.....	10
Testing.....	11
Operation.....	12
Web Portal.....	12
Using Your Mobile Phone.....	12
Reference.....	12
Control Module.....	12
LAN Port.....	13
Power.....	13
Troubleshooting.....	13
Solutions to Problems.....	14
Obtaining Support.....	15
Specifications.....	16

Introduction

Thank you for purchasing the BAYweb Integrator. This system is easily installed by home owners or an electrician. This model of BAYweb Integrator (BW-BCU3) supports up to 16 monitoring points and 16 control/set points.

About This Manual

This manual contains the information necessary for installing and operating the BAYweb Integrator system. However, since installations may vary, these instructions may not cover all details or variations in the equipment supplied or every question that may possibly arise during use.

If a question or situation develops which is not answered directly in this manual, contact BAYweb support for specific answers and advice. (See Obtaining Support section, page 15.)

You should become familiar with the contents of this manual before the BAYweb Integrator is put into service. This is particularly important with regard to the safety precautions listed in the Safety Precautions section, and those included at relevant points in other sections of this manual.

Note that this manual is updated periodically. You can download the latest version at www.bayweb.com.

Limited Warranty

Subject to the limitations contained below, and except as otherwise expressly provided herein, Seller warrants to the Buyer that all tangible articles supplied by Seller or services provided by Seller will be free of defects in materials or workmanship under normal use and care until the expiration of the applicable warranty period. Goods are warranted for five (5) years from the date of purchase. If Buyer discovers any defects and notifies Seller thereof in writing during the applicable warranty period, Seller shall at its option promptly correct, repair, or replace F.O.B. point of manufacture that portion of the good found by Seller to be defective, or refund the purchase price of the defective portion of the goods/services. All replacements or repairs necessitated by inadequate maintenance, normal wear and usage, unsuitable power sources, unsuitable environmental conditions, accident, misuse, improper installation, modification, repair, storage or handling, or any other cause not the fault of Seller are not covered by this limited warranty, and shall be at Buyer's expense. Seller shall not be obligated to pay any costs or charges incurred by Buyer except as may be agreed upon in writing in advance by an authorized Seller representative. Goods repaired and parts replaced during the warranty period shall be in warranty for the remainder of the original warranty period or ninety (90) days, whichever is longer.

THERE ARE NO REPRESENTATIONS OR WARRANTIES OF ANY KIND, EXPRESS OR IMPLIED, AS TO MERCHANTABILITY, FITNESS FOR PARTICULAR PURPOSE, OR ANY OTHER MATTER WITH RESPECT TO ANY GOODS OR SERVICES.

Limitation on Liability

THE SOLE AND EXCLUSIVE REMEDY FOR BREACH OF WARRANTY HEREUNDER SHALL BE LIMITED TO REPAIR, CORRECTION, REPLACEMENT OR REFUND OF PURCHASE PRICE AS PROVIDED UNDER THE FOREGOING LIMITED WARRANTY. IN NO EVENT, REGARDLESS OF THE FORM OF THE CLAIM OR CAUSE OF ACTION (WHETHER BASED IN CONTRACT, INFRINGEMENT, NEGLIGENCE, STRICT LIABILITY, TORT OR OTHERWISE), SHALL SELLER'S LIABILITY TO BUYER AND/OR ITS CUSTOMERS EXCEED THE PRICE TO THE BUYER OF THE SPECIFIC GOODS SUPPLIED OR SERVICES PROVIDED BY SELLER GIVING RISE TO THE CLAIM OR CAUSE OF ACTION.

BUYER AGREES THAT IN NO EVENT SHALL SELLER'S LIABILITY TO BUYER AND/OR ITS CUSTOMERS INCLUDE "CONSEQUENTIAL DAMAGES". FOR THIS PURPOSE, "CONSEQUENTIAL DAMAGES" SHALL INCLUDE, BUT NOT BE LIMITED TO, LOSS OF ANTICIPATED PROFITS, LOSS OF USE, LOSS OF REVENUE AND LOSS OF CAPITAL.

Unauthorized Repair

In the event that the owner allows the BAYweb Integrator module to be serviced or repaired by unauthorized personnel, the coverage of the original warranty policy will be automatically terminated.

BAYweb Integrator

The BAYweb Integrator provides the ability to quickly and economically add remote monitoring, control, and alerting capabilities to Programmable Logic Controllers (PLCs) and other dedicated devices.

Just plug the Integrator into the Internet and your system is online with your personal web portal.



Monitoring Points

The BAYweb Integrator acquires up to 16 points of data from one or more PLCs and uploads the data to our database servers every 10 seconds.

The monitoring points are configured using an applet on the web portal. The Integrator converts and scales the PLC data into the appropriate units and data format based on the point configuration. This provides the ability to easily convert the output from sensors and transducers to the desired unit of measure, directly usable for reporting and alerting.

The integrator supports the following PLC data formats: digital (ON/OFF), analog (16 bit signed or unsigned, or binary coded decimal), and counter (16 and 32 bit).

Analog data is converted into 32 bit floating point values and scaled using a configurable offset, span, and precision. The counter data type is typically used to sum a measurement, such as power consumption. This provides the ability to measure usage that is not affected by a loss of Internet connectivity.

Alert Handling

Upon sensing an alert condition, the alert device will immediately send a message to our data center, which in turn will send the alert message to the list of recipients configured for that point.

Nominal response time for dispatching the notification message from our data center is three seconds. Delivery time of the message is dependent on your Internet or mobile provider.

Once an alert has been sent, it will not be sent again until a configurable time period has elapsed for that point. An alert is also provided if the Internet connection goes down, and when it is restored.

The alert system can be armed or disarmed using the web and/or mobile portals.

Control Points

The Integrator can write up to 16 different control or set points to one or more PLCs with a nominal maximum response time of 10 seconds.

Similar to monitoring points, the control point data is converted and scaled into the appropriate units and data format based on the point configuration.

The control points may be modified from the BAYweb Portal.

Installation

Overview

Installing the BAYweb Integrator system is a relatively simple process and typically takes from 10 to 30 minutes to complete. You will need screwdrivers, a wire stripper/cutter, and a drill for installing the wall anchors to complete the installation.

The BAYweb Integrator module may be mounted in a convenient location that allows easy access to Ethernet, AC power and serial port cables.

You will need an Internet connection.

If it is not convenient to plug into your network there, consider using an optional power-line Ethernet adapter.



1

Install BAYweb Integrator

- A) Mount the module using the following criteria:
 - Select a location with easy access to Modbus serial communications.
 - Select a location within six feet of a power outlet, ideally on the same circuit as the PLC system.
 - Select a location where you can connect to the Internet. If wiring is not convenient, we suggest using a power line Ethernet adapter that will allow you to make this connection using your existing power wiring.
- B) Mount the BAYweb Integrator module with the provided wall anchors and screws.
- C) Make sure that the power adapter is not plugged in. Connect the positive lead to the PWR+ terminal and the negative lead to the PWR- terminal. Verify that the polarity is correct. The module can be damaged if the power is reversed.
- D) Apply power and make sure that the Power LED flashes (3-5 per second). This indicates that the module is powered and ready to be communicate.
- E) Remove power and proceed to the next step.

2

Connect to the Internet

Now that you have the BAYweb Integrator installed and configured, it is time to connect it to the Internet.

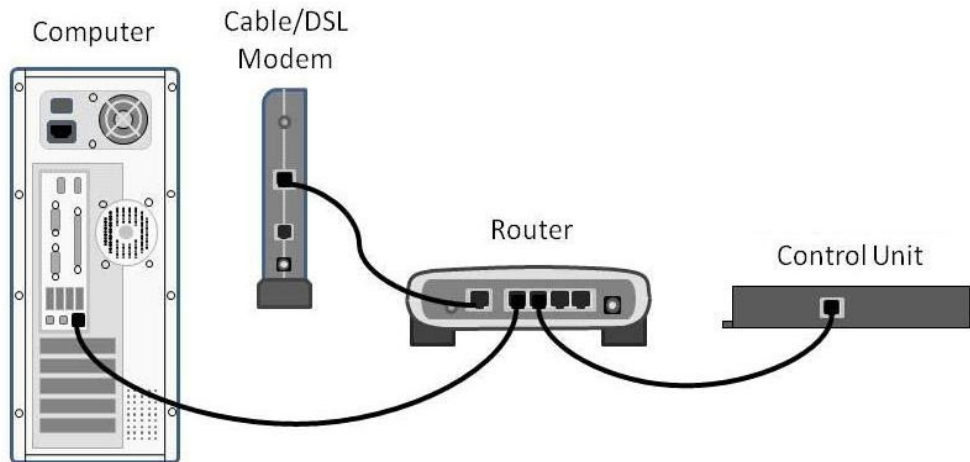

- A) Connect the module to the Internet. Plug one end of an Ethernet cable into the LAN port on the bottom of the BAYweb Integrator module and the other end into a port on a router or switch on your home network.
- B) If direct wiring is not convenient, use Power line Ethernet adapters. Plug one adapter into a power plug near the control module, and the other adapter near your home router. Then just plug the Ethernet cables into the adapters and the ports.

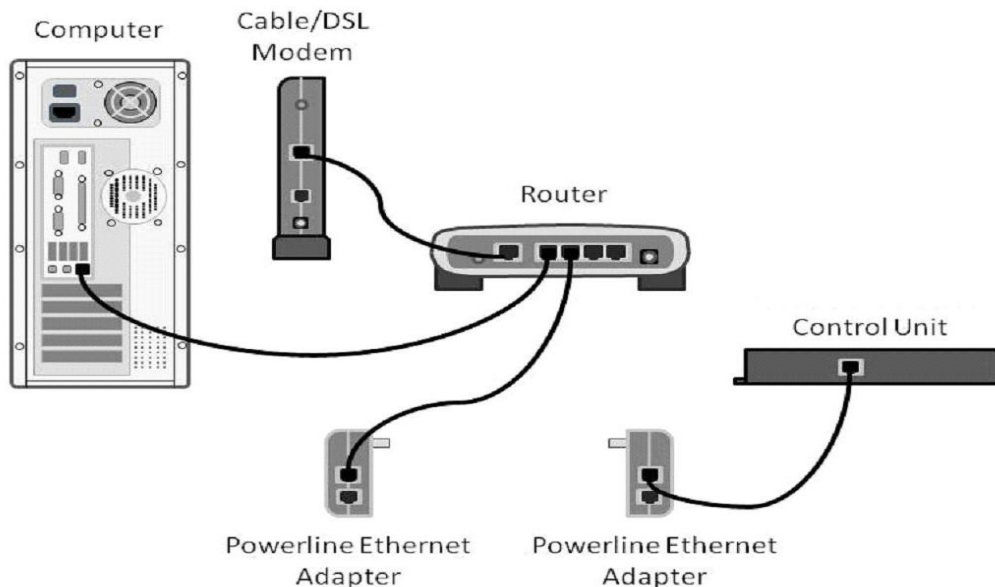

- C) The BAYweb Integrator does not require any configuration or programming of your networking equipment. You do not need to change security settings. Just plug it in and you are all set to go.
- D) In less than a minute the “Uplink” light should illuminate on the module. If it does, your BAYweb Integrator is on line and ready to go. If you do not see “Uplink” light up within a couple of minutes, refer to the Troubleshooting section of this manual.

3

Connecting Modbus

Modbus

The BAYweb Integrator provides two methods of communicating with the PLC; using the RS-485 serial port, and using the LAN (Ethernet) port. Both ports may be used simultaneously. Each monitoring and control point may be mapped to any PLC that is connected to the Integrator.

Serial Modbus

The BAYweb Integrator supports standard RS-485 serial Modbus at baud rates of 4800, 9600, 19200 and 38400 bps.

Connect the two wires of the RS-485 serial to the COM+ and COM- terminals on the BAYweb Integrator. COM+ should be wired to the “A” or “+” wire and COM- should be wired to the “B” or “-” wire.

Modbus TCP (Ethernet)

If using Modbus TCP, no additional wiring is required. The LAN port will be used both to communicate with the BAYweb Portal and to communicate with the Modbus TCP Servers.

4

Configuration

Once you have installed your equipment, login to the web portal to configure them. Use the BAYweb Portal to access and configure your module. This portal can be accessed anytime from anywhere via web browser and Internet enabled mobile phone. Unlimited use of the portal is included at no charge.

To setup your personalized portal go to the web site (www.bayweb.com), register a new account, login and add a device (your BAYweb Integrator module). You will need the serial number and key code that are on the front of this manual.

Please refer to the online help file for details on configuring the BAYweb Integrator.

5

Testing

- A) Make sure that the BAYweb Integrator is connected to the Internet and powered on.
- B) Verify that the “Power” light is flashing on the control module.
- C) Verify that the Uplink light is on. This indicates that the module is communicating with the BAYweb servers.
- D) If Modbus Serial points are configured, the Transmit and Receive lights should be flashing. The Transmit LED indicates that a serial request has been sent. The Receive LED indicates that serial data has been received.
- E) Go to the BAYweb Portal and view the data to verify that the expected data is being displayed. Allow 10-30 seconds to be sure that the data has had time to cycle through the system.

Operation

Web Portal

Use the BAYweb Portal to access and configure your module. This portal can be accessed anytime from anywhere via web browser and Internet enabled mobile phone. Unlimited use of the portal is included at no charge.

Using Your Mobile Phone

Once you have setup your personalized web portal, you can also use most any mobile phone that has web access to remotely access your device and other web devices. To access the mobile web portal, enter the following address in your mobile phone browser:
www.bayweb.com/mobile.

Reference

Control Module



LAN Port

The LAN port is a standard Ethernet interface (IEEE 802.3 compatible with 10/100/1000 Base-T networks). This port operates at 10 Mbps (10Base-T). There are 2 LED activity indicators built into the the connector. The green LED will be illuminated whenever there is a physical link to your network (plugged in). The amber LED is illuminated when there is activity on the port.

Power

The wall transformer is used to power the BAYweb Integrator. This is a standard 12 VDC, 0.5A adapter. Alternative power may be used to power the BAYweb Integrator provided it does not exceed the specified voltage range.

Troubleshooting

We encourage you to communicate any problems you have encountered to us, even if you are able to solve them on your own. We would also like to have any suggestions or comments about the installation procedure.

The preferred method of communicating with us is via email. We use an automated tracking system to insure that we respond to your messages in the quickest possible time, and provide the shortest path to problem resolution. Our support email address is support@bayweb.com. We also have an on line support page that you can use to send a message to our support staff.

When contacting us for support, please provide your name and your serial number. We may also request your key code to validate that you have a given piece of equipment. The serial number and key code are located on the front cover of this manual and on the Control Module.

We suggest you review the Solutions to Problems section and check the support resources on www.bayweb.com which may provide you with a simple solution to the problem.

Solutions to Problems

Problem	Solution
No Control Module power indication.	<ul style="list-style-type: none"> ➤ Check for power at outlet. ➤ Make sure that the wires are correctly installed in the terminals. ➤ Make sure that the insulation is adequately stripped so that a good connection is made in the terminals. ➤ Contact support for replacement module.
Control module not connecting to Internet, Uplink light does not come on.	<ul style="list-style-type: none"> ➤ Verify that the green LED on the LAN connector (on the side of the Control Module) is illuminated. ➤ Verify that the amber LED on the LAN connector is blinking. ➤ Plug a laptop or PC into the connection you are using for the thermostat and verify that you can browse to “https://www.bayweb.com”.
Transmit light not flashing. (No serial data is being transmitted)	<ul style="list-style-type: none"> ➤ Verify that the module is in contact with the BAYweb servers in order to get the configuration (Uplink light is ON) ➤ Verify that valid serial points are configured. If no serial points are configured, it will not use the serial port.
Receive light not flashing, Transmit is flashing. (no response from Modbus device)	<ul style="list-style-type: none"> ➤ Verify that the Modbus device is powered. ➤ Make sure that the Modbus ID on the device matches the configured ID on the BAYweb Integrator. ➤ Make sure that the speed and data format are correct. ➤ Verify wiring polarity. Try switching the COM+ and COM- terminals.

Obtaining Support

Customer support is available every day of the year, including holidays, via email to support@bayweb.com. Be sure to include your product serial number in your message, we can not help you without it.

We typically respond to support emails within 20 minutes between 8 AM and midnight, Eastern time. Support requests received after midnight are handled the following morning.

Specifications



Part Number:	BW-BCU3
Applications:	Residential, commercial
Serial Port Data Rate:	4800, 9600, 19200 & 38400 baud
Serial Port Data Format:	8-bit, 1 stop bit, selectable parity
Shipping Temperature Range:	-40° to 150° F
Operating Temperature Range:	0° to 120° F
Operating Relative Humidity:	5% to 90% (non-condensing)
Power Method:	Independently powered
Power Requirements:	12-24 VDC, 0.05 Amp maximum
Dimensions:	4.0" W x 2.75" H x 1.125" D
Weight:	4.5 oz